

AC2270

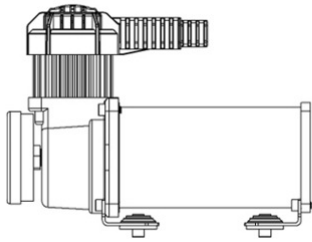

**VEHICLE MOUNTED
COMPRESSOR
SUPPLIED
SEPARATELY**



**1/4" NPT TEE FITTING
FOR DUAL OUTLET**

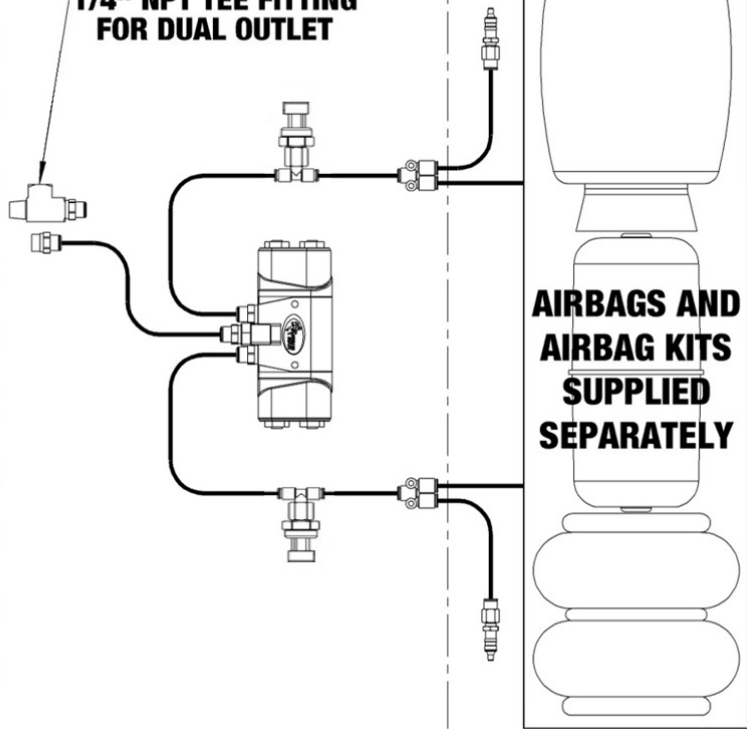

**AIRBAGS AND
AIRBAG KITS
SUPPLIED
SEPARATELY**



**VEHICLE MOUNTED
COMPRESSOR SUPPLIED
SEPARATELY**

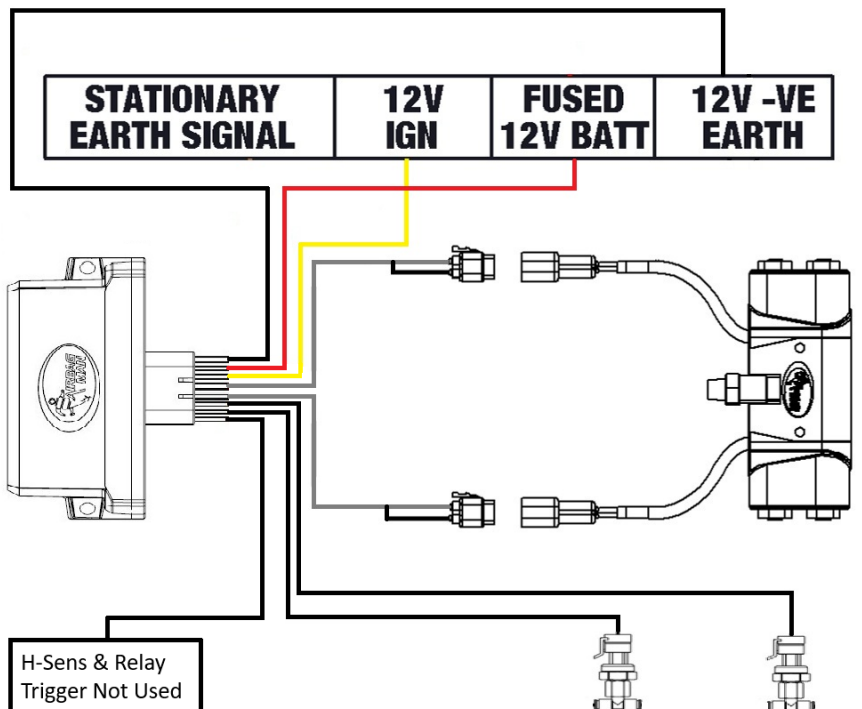
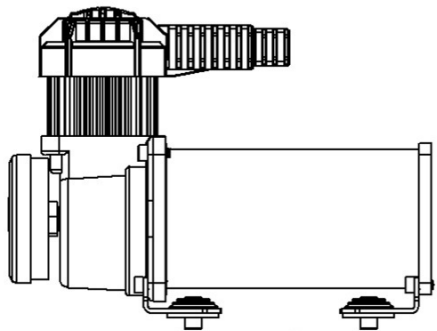



- **It is recommended that a properly qualified person installs the product and carries out maintenance. If you are not qualified, ensure that all safety standards are followed.**
- **Read Product Manual before fitting the product.**
- **Ensure the Product Manual and Installation Instructions remain with the vehicle. Ensure any vehicle operators are advised on the system and its operation before driving or operating.**
- **DO NOT connect any electrical components to the vehicle without preparing the electrical system as per the vehicle manufacturer's instructions. Connecting without preparing the vehicle could lead to component failure, vehicle damage or fire.**
- **In some Countries, States or Territories it may not be legal to position controls inside a vehicle or within reach while operating the vehicle. Confirm with your relevant authorities.**
- **Air compressors get hot - avoid any flammable liquid or burn risk areas.**
- **Ensure the system pressure never exceeds the Maximum Working Pressure printed on the Air tank.**
- **Incorrect use of this product can result in damage to the components, associated parts and/or the vehicle, which is not covered under warranty.**
- **Ensure suspension airbags are always maintained at the stated Operating Height within the Minimum and Maximum pressures stated for each Airbag Man product.**



- **Prepare the vehicle according to the vehicle manufacturer's instructions regarding electrical connection/disconnection, component positioning, and mounting.**
- **DO NOT remove, attach, drill, or modify the vehicle without instruction from the vehicle manufacturer.**
- **DO NOT connect electronic components such as the digital gauge or wireless controller to a fluctuating power supply, such as a dual battery circuit or battery charging circuit. This can damage electronic components.**



AIR LINE TUBE

- Cut square with utility knife or tube cutter.
- Do not use pliers, side cutters or pipe cutters.
- Ensure no scratches or deformation of air line before connecting.
- No routing near heat or sharp edges.
- Ensure airline curves are greater than 75mm radius.

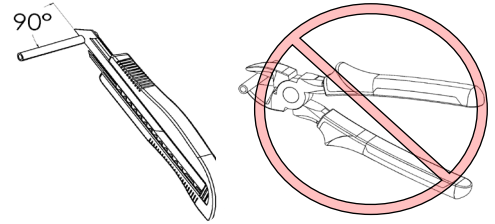

PUSH TO CONNECT FITTINGS

- **CONNECT** – Push tube to a depth of 10–12mm.
- **DISCONNECT** – Remove all air pressure. Then push the collar down while pulling tube out.

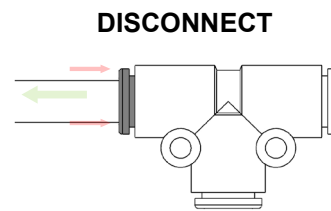
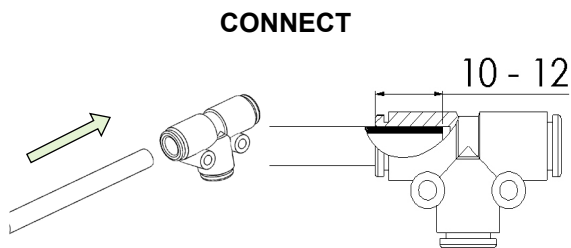

BARBED FITTINGS

- **CONNECT** – Push the air line tube onto the barb with a side-to-side motion until completely seated onto the barb. Heating the connection end with hot water will soften the tube to help.
- **DISCONNECT** – Cut tube to 50mm and use hot water to soften the tube. Using pliers, pull the tube away from the barb. Only submerge the barb, not the entire part. Warranty voided if barb is damaged from cutting.

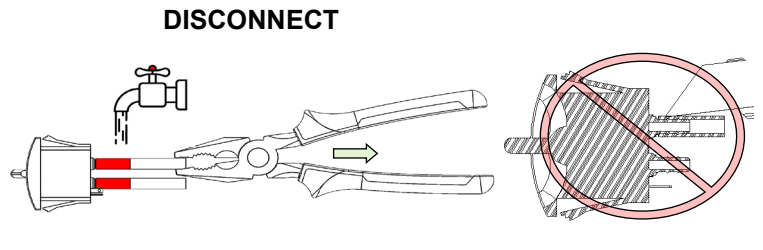
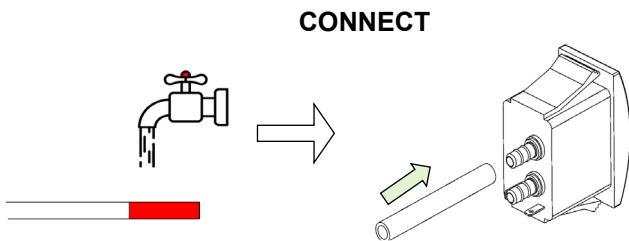

THREADED FITTINGS

- Fittings with white nylon sealing ring- Tighten to the white nylon sealing ring, then tighten a further 3/4 turn to finish. No additional thread sealant required. Reuse of these fittings can degrade the sealing ring.
- Fittings with pre applied sealant- Tighten the fitting until snug. These fittings are tapered and when sealed some threads may still be visible, ensure a leak test is performed to confirm there are no leaks.

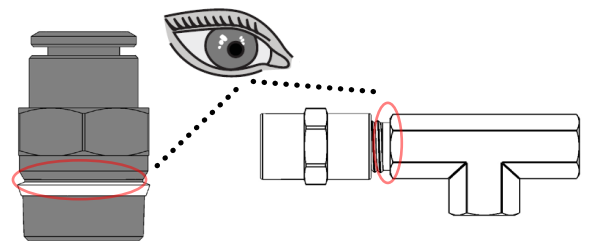



COMPONENT MOUNTING

- Flat, rigid, and secure. Ensure clearance for wiring and/or air lines.
- Close to the Battery. It is better to use more air line tubing than more electrical wiring.
- Cool location with air flow.
- Mount in a protected location. Avoid positions that objects may strike and where excessive dust or debris can collect.
- Components are splash resistant; ensure they cannot be submerged in water.

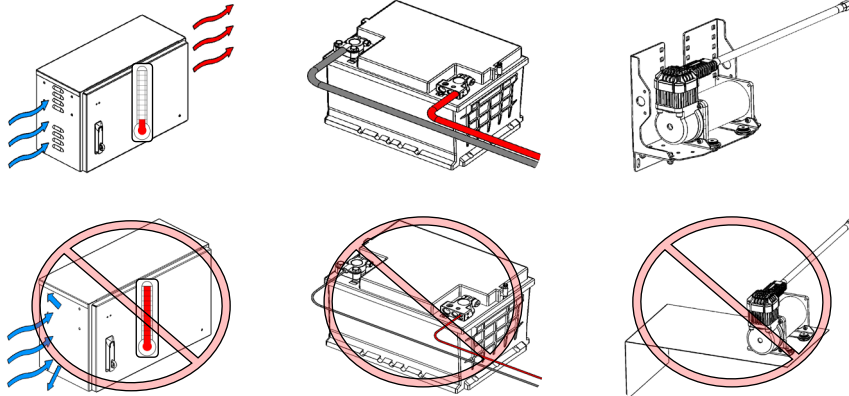

FASTENERS

- Use supplied fasteners where appropriate. If alternate fasteners are required ensure these meet the component and vehicle requirements.
- Recheck fasteners are secure after initial installation

AIR INLET FILTER

- **COMPRESSOR IN PROTECTED POSITION** – The air filter can be mounted close to the compressor inlet.
- **COMPRESSOR UNPROTECTED** – The air filter must be remotely mounted using the supplied parts as shown below.

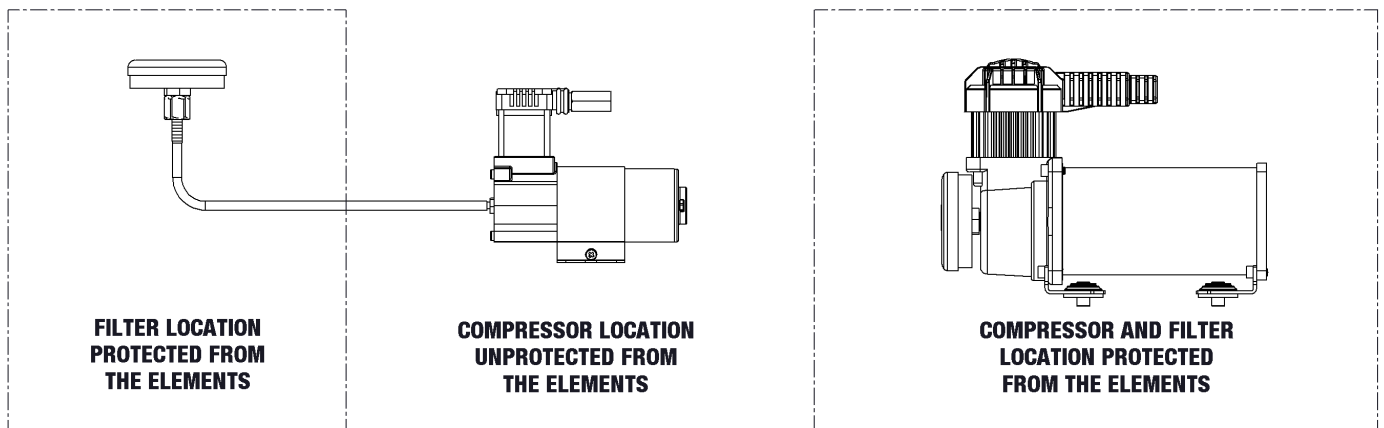

CONNECTIONS AND WIRING

- Use supplied terminals, components and wiring where appropriate. If alternate parts are required ensure these meet the component and vehicle requirements.
- Check Compressor specifications on the label to ensure compatibility of any wiring and connection changes.
- Do not route wiring near heat surfaces or sharp edges.
- Unused Connections, for installs not using the 86 Compressor relay and for the H/ Sens connectors, please cover the ends. For applications where these connectors are external, use a sealing heat shrink or similar

AIRBAG MAN ECU

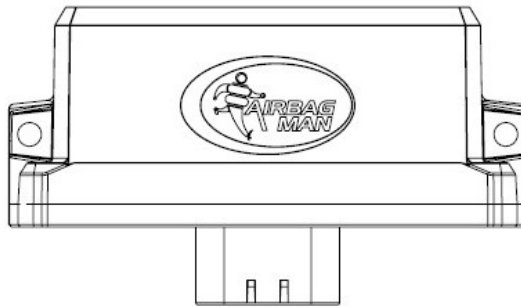

- **Install the Airbag Man App to your device from your App source.**
- **The ECU must be powered up and your device Bluetooth On, then connect to the Airbag Man device.**
- **Please see the Product Manual for further information on Settings and User operation.**

AIR CONTROL – DIMENSIONS

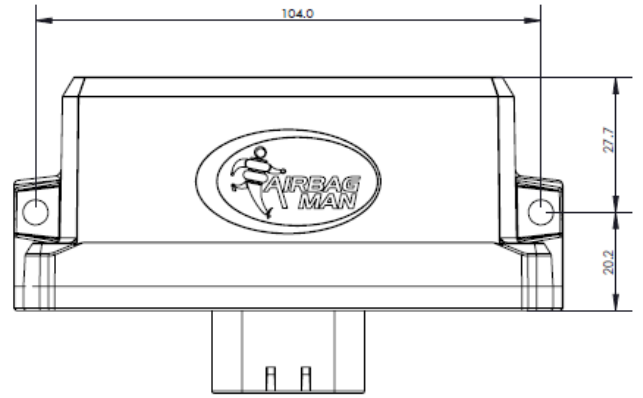
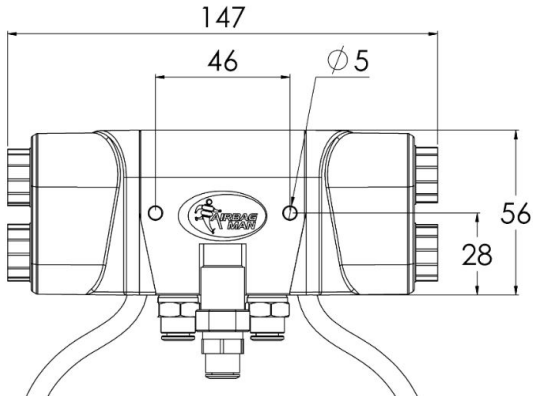

AIR CONTROL – FASTENING

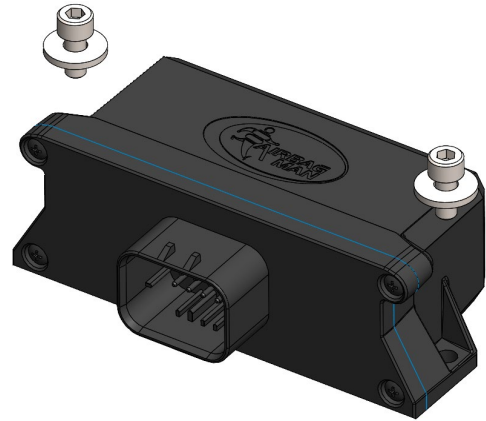
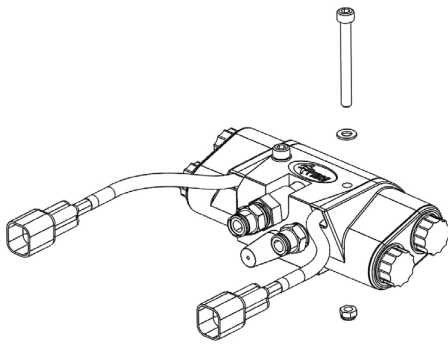

AIR CONTROL – ELECTRICAL AND PNEUMATIC CONNECTIONS

ELECTRICAL- Connect ECU connector, Valve and Pressure Sensors as well as the Battery +12v, Ground , Ignition connections.

PNEUMATIC- Connect the air supply to the valve block using the supplied fittings. Then connect the the Left and right airbag outlets with pressure sensors inline.

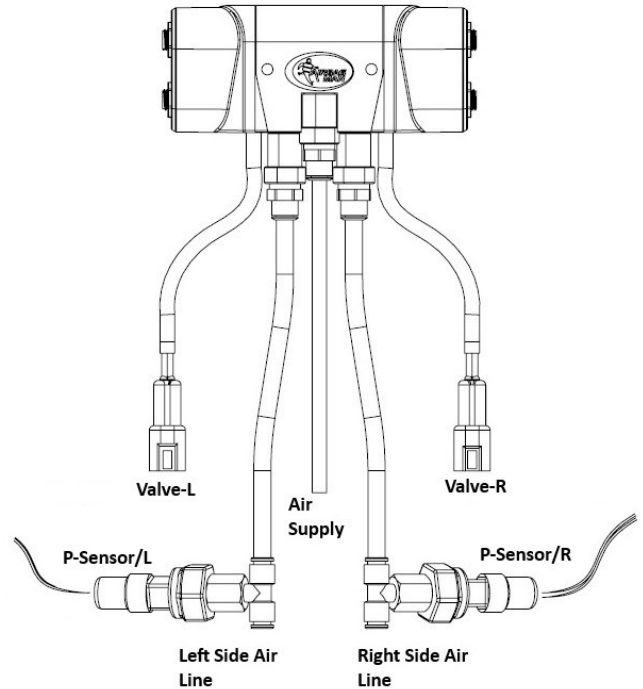

Unused Connections, for installs not using the 86 Compressor relay and for the the H/ Sens connectors, please cover the ends. For applications where these connectors are external, use a sealing heat shrink or similar



INFLATE the air supply and airbags to their maximum allowed pressure (See Pressure Advice in Airbag Owner's Manual) and check for leaks using soapy water spray. We recommend a soapy water spray solution of 25% soap to 75% water.

DEFLATE airbags to required height if no leaks. If leaks are detected, deflate airbags and air supply, tighten and check the air fittings (if required), remove the air line tubing, re-cut, and re-test.

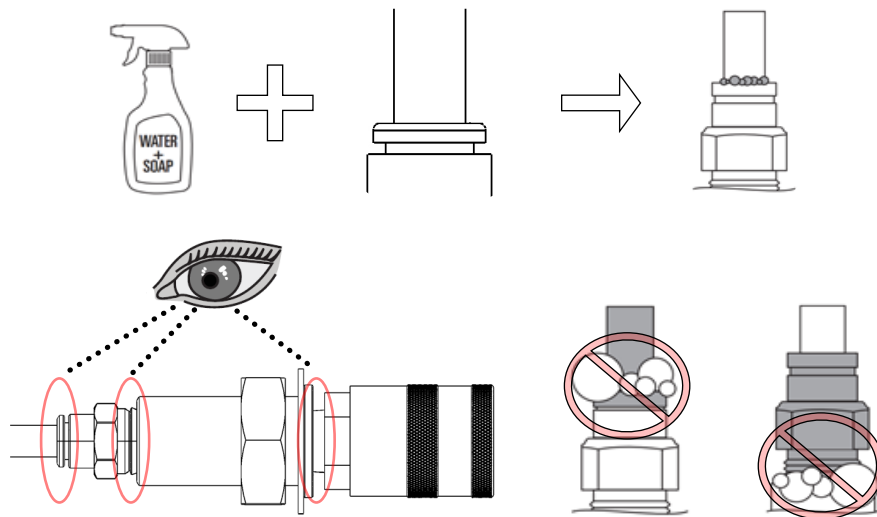

⚠ Ensure airbags are returned to correct height (see Airbag Kit Fitting Instructions) after Leak Test is completed.



- **Reattach all components removed earlier and return the vehicle to driving position. Ensure this operation is carried out according to the vehicle manufacturer's instructions.**
- **Ensure the Product Manual and Installation Instructions remain with the vehicle. Ensure any vehicle operators are advised on the system and its operation before driving or operating.**



- Periodically check that the Compressor air filter is clean. Replacement filters are provided and may need frequent replacement if operating in a dusty environment.
- Regularly clean dust and debris from the compressor fins and motor housing.
- Periodically check the electrical and pneumatic connections are tight and not damaged.
- Periodically check the fasteners are tight and not damaged.
- The Compressor is equipped with a permanently lubricated, maintenance-free motor. Never try to lubricate the air compressor.
- If the Compressor runs for a long period of time it may turn off due thermal protector. If this occurs, turn the power off and allow the unit to cool for about 30 minutes. This will allow the protector to reset, after which resume use.
- If the Compressor run time increases or is blowing fuses check that the battery voltage is sufficient, the wiring is suitable and in good condition. If all the electrical components appear correct, then check that the compressor has adequate ventilation and is clean. If problems continue the compressor may be worn out and in need of replacement.